

概述

BIP60015G-A 是比亚迪公司最新设计开发的超小型封装智能功率模块 (IPM-Intelligent Power Module)。该产品具有封装超小、抗干扰能力强等优点; 实现了与绝缘栅双极型晶体管 (IGBT) 的最佳匹配。内部集成了欠压闭锁电路、过流保护电路和驱动电路, 进一步提高了系统的可靠性。内置的高压集成电路 (HVIC) 提供了无需光耦隔离的驱动功能。由于采用了分立的负端子, 可独立监测逆变器的每一相电流。该产品适用于结构紧凑、性能高效的交流电机驱动器, 如小功率变频器、变频空调等领域。

General Description

BIP60015G-A is an advanced intelligent power module that BYD has newly developed and designed to provide very compact and high performance as ac motor drivers mainly targeting low-power inverter-driven applications like air conditioner and washing machine. It combines optimized circuit protection and drive matched to low-loss IGBT. System reliability is further enhanced by the integrated under-voltage lock-out and Over-current protection. The high speed built-in HVIC provides opto-coupler-less single-supply IGBT gate driving capability that further reduce the overall size of the inverter system design. Each phase current of inverter can be monitored separately due to the divided negative dc terminals.

产品特性

- 采用陶瓷覆铜板 (DBC), 低热阻设计
- 600V 15A三相IGBT逆变器, 内置门极驱动和功率器件保护用控制IC
- 分立的三相直流负端, 可独立检测相电流
- 内置高压集成电路(HVIC)和自举二极管, 可采用单电源驱动
- 内置温度电压输出功能

Features

- Very low thermal resistance due to using DBC
- 600V 15A Three-phase IGBT inverter bridge including control ICs for gate driving and protection
- Divided negative dc-link terminals for inverter current sensing applications
- Single-grounded power supply due to built-in HVIC and bootstrap diode
- Outputting LVIC temperature by analog signal

应用领域

- 空调、洗衣机等变频家电
- 小功率变频器
- 伺服控制系统
- 小功率交流电机传动系统使用的三相逆变器

Applications

- Three-phase inverter drive for small power ac motor control
- Home appliances applications like air conditioner and washing machine

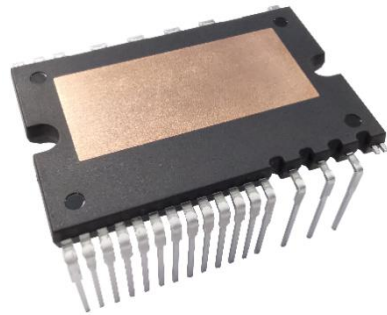

封装/Package

BIP25-3824

内部等效电路/Internal Equivalent Circuit



图1. 内部等效电路
Fig 1. Internal Equivalent Circuit

引脚布局/Pin Configuration



图 2. 引脚布局图(top view)
Fig 2. Pin Configuration(Top View)

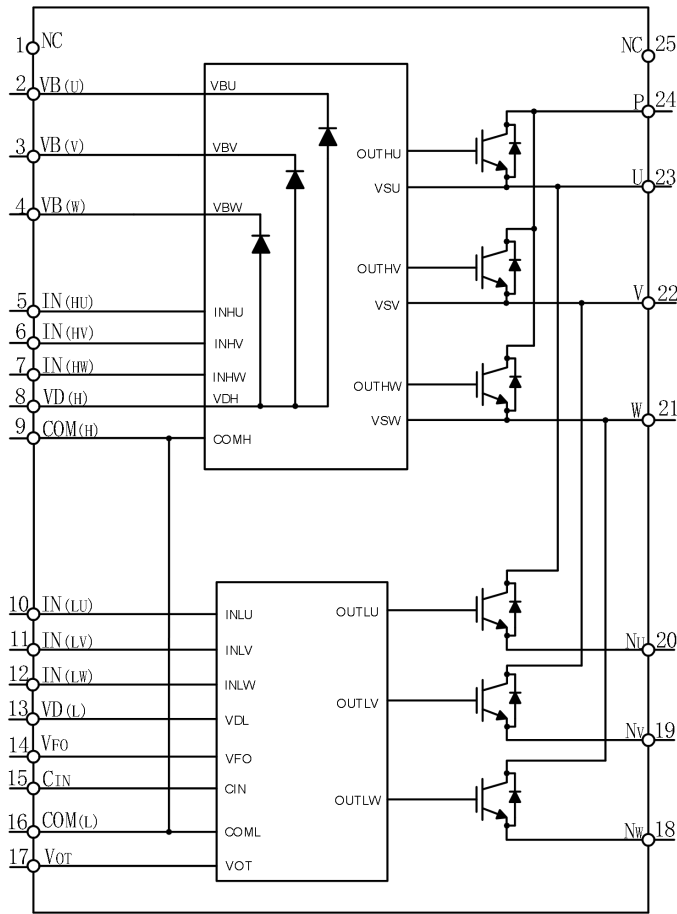

引脚描述/Pin Descriptions

引脚号 Pin	引脚名 Name	描述 Descriptions
1	NC	无连接 No connection
2	VB(U)	U 相上臂驱动电源端 Drive power terminal for high side U phase
3	VB(V)	V 相上臂驱动电源端 Drive power terminal for high side V phase
4	VB(W)	W 相上臂驱动电源端 Drive power terminal for high side W phase
5	IN(HU)	U 相上臂控制信号输入端 Control signal input for high side U phase
6	IN(HV)	V 相上臂控制信号输入端 Control signal input for high side V phase
7	IN(HW)	W 相上臂控制信号输入端 Control signal input for high side W phase
8	VD(H)	上臂控制电源端 High side control power supply
9	COM(H)	上臂控制电源 GND 端 GND terminal of high side control power supply
10	IN(LU)	U 相下臂控制信号输入端 Control signal input for low side U phase
11	IN(LV)	V 相下臂控制信号输入端 Control signal input for low side V phase
12	IN(LW)	W 相下臂控制信号输入端 Control signal input for low side W phase
13	VD(L)	下臂控制电源端 Low side control power supply
14	VFO	故障输出端 Fault output
15	CIN	短路电流检测输入端 Capacitor (low-pass Filter) for over-current detection input
16	COM(L)	下臂控制电源 GND 端 GND terminal of low side control power supply
17	VOT	温度电压输出端 Temperature analog output
18	NW	W 相下臂 IGBT 发射极端 Emitter for low side W phase
19	NV	V 相下臂 IGBT 发射极端 Emitter for low side V phase
20	NU	U 相下臂 IGBT 发射极端 Emitter for low side U phase
21	W	W 相输出端 output for W phase
22	V	V 相输出端

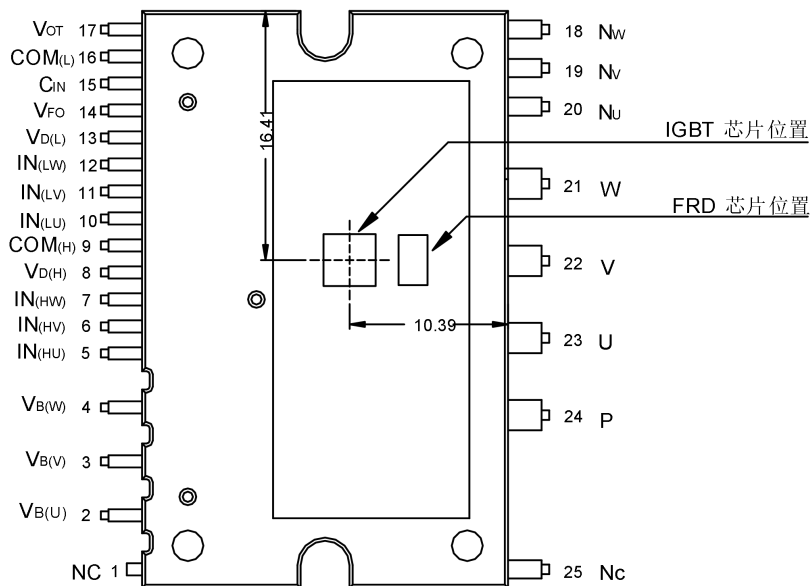

		output for V phase
23	U	U 相输出端 output for U phase
24	P	逆变器直流输入端 DC input of inverter
25	NC	无连接 No connection

最大绝对额定值/Absolute Maximum Ratings

($T_J=25^{\circ}\text{C}$,除非另外注明/unless otherwise noted)

逆变器部分/Inverter Part

符号 Symbol	参数 Parameter	工作条件 Conditions	额定值 Ratings	单位 Units
V_{PN}	电源电压 Supply voltage	施加在 P-N _U , N _V , N _W 之间 Applied between P-N _U , N _V , N _W	450	V
$V_{PN}(\text{surge})$	电源 (浪涌) Supply voltage (surge)	施加在 P-N _U , N _V , N _W 之间 Applied between P-N _U , N _V , N _W	500	V
V_{CES}	集电极-发射极之间电压 Collector-emitter voltage	$V_{GE}=0\text{V}$, $I_C=0.1\text{mA}$, $T_J=25^{\circ}\text{C}$	600	V
$\pm I_C$	单颗 IGBT 集电极电流 Each IGBT collector current	$T_C = 25^{\circ}\text{C}$	15	A
$\pm I_{CP}$	单颗 IGBT 集电极电流 (峰值) Each IGBT collector current (peak)	$T_C = 25^{\circ}\text{C}$, 持续 1ms 的脉冲宽度 $T_C = 25^{\circ}\text{C}$, less than 1ms	30	A
P_C	集电极功耗 Collector dissipation	$T_C = 25^{\circ}\text{C}$, 每一片 $T_C = 25^{\circ}\text{C}$, per 1 chip	41	W
T_J	结温 Junction temperature	(注 1/Note 1)	-40~+150	$^{\circ}\text{C}$

注 1: 智能功率模块中集成的功率芯片的最大结温额定值为 150°C ($@T_C \leq 100^{\circ}\text{C}$)。但是, 为了确保智能功率模块的安全工作, 平均结温应限制为 $T_J(\text{ave}) \leq 125^{\circ}\text{C}$ ($@T_C \leq 100^{\circ}\text{C}$)。

Note 1: The maximum junction temperature rating of the power chips integrated within the IPM is 150°C ($@T_C \leq 100^{\circ}\text{C}$). However, to ensure safe operation of the IPM, the average junction temperature should be limited to $T_J(\text{ave}) \leq 125^{\circ}\text{C}$ ($@T_C \leq 100^{\circ}\text{C}$).

控制部分/Control Part

符号 Symbol	参数 Parameter	工作条件 Conditions	额定值 Ratings	单位 Units
V_D	控制电源电压 Control power supply voltage	施加在 $V_{D(H)}\text{-COM}_{(H)}$, $V_{D(L)}\text{-COM}_{(L)}$ 之间 Applied between $V_{D(H)}\text{-COM}_{(H)}$, $V_{D(L)}\text{-COM}_{(L)}$	-0.3~20	V
V_{DB}	高端控制辅助供电 High side control supply voltage	施加在 $V_{B(U)}\text{-U}$, $V_{B(V)}\text{-V}$, $V_{B(W)}\text{-W}$ 之间 Applied between $V_{B(U)}\text{-U}$, $V_{B(V)}\text{-V}$, $V_{B(W)}\text{-W}$	-0.3~20	V
V_{IN}	输入电压 Input voltage	施加在 $IN_{(HU)}$, $IN_{(HV)}$, $IN_{(HW)}\text{-COM}_{(H)}$, $IN_{(LU)}$, $IN_{(LV)}$, $IN_{(LW)}\text{-COM}_{(L)}$ 之间 Applied between $IN_{(HU)}$, $IN_{(HV)}$, $IN_{(HW)}\text{-COM}_{(H)}$, $IN_{(LU)}$, $IN_{(LV)}$, $IN_{(LW)}\text{-COM}_{(L)}$	-0.3~ $V_D+0.3$	V
V_{FO}	故障输出电压 Fault output voltage	施加在 $V_{FO}\text{-COM}_{(L)}$ 之间 Applied between $V_{FO}\text{-COM}_{(L)}$	-0.3~ $V_D+0.3$	V



I_{FO}	故障输出电流 Fault output current	在引脚 V_{FO} 处灌电流 Sink current at V_{FO} terminal	2	mA
V_{CIN}	电流检测输入电压 Current sensing input voltage	施加在 C_{IN} - $COM_{(L)}$ 之间 Applied between C_{IN} - $COM_{(L)}$	$-0.3 \sim V_D + 0.3$	V

整个系统/Total System

符号 Symbol	参数 Parameter	工作条件 Conditions	额定值 Ratings	单位 Units
$V_{PN(Prot)}$	自保护电源电压限制（短路保护能力） Self protection supply voltage limit (short circuit protection capability)	$V_D = 13.5 \sim 16.5V$, $T_J = 125^\circ C$, 非重复性, 小于 5 us $V_D = 13.5 \sim 16.5V$, inverter part $T_J = 125^\circ C$, non-repetitive, less than 5us	400	V
T_C	模块壳体工作温度 Module case operation temperature	$-40^\circ C \leq T_J \leq 150^\circ C$, 图 2 (Fig 2.)	$-40 \sim +125$	$^\circ C$
T_{STG}	存储/保存温度 Storage temperature		$-40 \sim +125$	$^\circ C$
V_{ISO}	绝缘电压/Isolation voltage	60Hz, 正弦波形, 交流 1 分钟, 所有引脚与散热器之间 60Hz, sinusoidal, AC 1 minute, connection pins to heat sink plate	1500	Vrms

热阻/Thermal Resistance

符号 Symbol	参数 Parameter	工作条件 Conditions	最小值 Min.	典型值 Typ.	最大值 Max.	单位 Units
$R_{th(j-c)Q}$	结点-壳体的热阻	逆变器 IGBT 部分（每 1/6 模块） Inverter IGBT part (per 1/6 module)	-	-	3.0	$^\circ C/W$
$R_{th(j-c)F}$	Junction to case thermal resistance	逆变器 FRD 部分（每 1/6 模块） Inverter FRD part (per 1/6 module)	-	-	3.8	$^\circ C/W$

电气特性/Electrical Characteristics

($T_J = 25^\circ C$, 除非另外注明/unless otherwise noted)

逆变器部分/Inverter Part

符号 Symbol	参数说明 Parameter	工作条件 Conditions	最小值 Min.	典型值 Typ.	最大值 Max.	单位 Units
$V_{CE(SAT)}$	集电极-发射极间饱和电压 Collector-emitter saturation voltage	$V_D = V_{BS} = 15V$, $V_{IN} = 5V$, $I_C = 15A$, $T_J = 25^\circ C$	-	1.7	2.2	V
V_F	FRD 正向电压 FRD forward voltage	$V_{IN} = 0V$, $I_C = 15A$, $T_J = 25^\circ C$	-	1.8	2.3	
I_{CES}	集电极-发射极间漏电流 Collector-Emitter leakage current	$V_{CE} = V_{CES}$, $V_{GE} = 0V$, $T_J = 25^\circ C$	-	-	0.1	mA



高端 High side	t_{ON}	开通时间 Turn-on time	$V_{PN}=400V,$ $V_D=V_{BS}=15V, I_C = 15A,$ $V_{IN} = 0\sim 5V, T_J = 25^\circ C,$ 感性负载 (注 2) Inductive load (Note 2)	-	720	-	ns
	$t_{C(ON)}$	开通交叉时间 Turn-on across time		-	200	-	ns
	t_{rr}	反向恢复时间 Reverse recovery time		-	180	-	ns
	t_{OFF}	关断时间 Turn-off time		-	560	-	ns
	$t_{C(OFF)}$	关断交叉时间 Turn-off across time		-	75	-	ns
低端 Low side	t_{ON}	开通时间 Turn-on time		-	840	-	ns
	$t_{C(ON)}$	开通交叉时间 Turn-on across time		-	260	-	ns
	t_{rr}	反向恢复时间 Reverse recovery time		-	180	-	ns
	t_{OFF}	关断时间 Turn-off time		-	580	-	ns
	$t_{C(OFF)}$	关断交叉时间 Turn-off across time		-	65	-	ns

注 2: t_{ON} 和 t_{OFF} 包括模块内部驱动集成电路(IC) 的传输延迟时间。 $t_{C(ON)}$ 和 $t_{C(OFF)}$ 指在内部给定的门极驱动条件下, IGBT 本身的切换时间。详细信息, 参考图 3。

Note 2 : t_{on} and t_{off} include the propagation delay time of the internal drive IC. $t_{c(on)}$ and $t_{c(off)}$ are the switching time of IGBT itself under the given gate driving condition internally. See figure 3.



图 3.开关时间定义
Fig 3. Switching Time Definition

控制部分/Control Part

符号 Symbol	参数 Parameter	工作条件 Conditions		最小值 Min.	典型值 Typ.	最大值 Max.	单位 Units
I_{DL}	V_D 静态电流 Quiescent V_D supply current	$V_{D(L)}=15V,$ $I_{N(LU,LV,LW)}=0$ V	$V_{D(L)}-COM_{(L)}$	---	---	1.0	mA
I_{DH}		$V_{D(H)}=15V,$ $I_{N(HU,HV,HW)}=0$ V	$V_{D(HW)}-COM_{(H)}$	---	---	600	
I_{QBS}	V_{BS} 静态电流 Quiescent V_{BS} supply current	$V_{BS}=15V,$ $I_{N(HU,HV,HW)}=0$ V	$V_{B(U)-U}, V_{B(V)-V},$ $V_{B(W)-W}$	---	---	200	uA

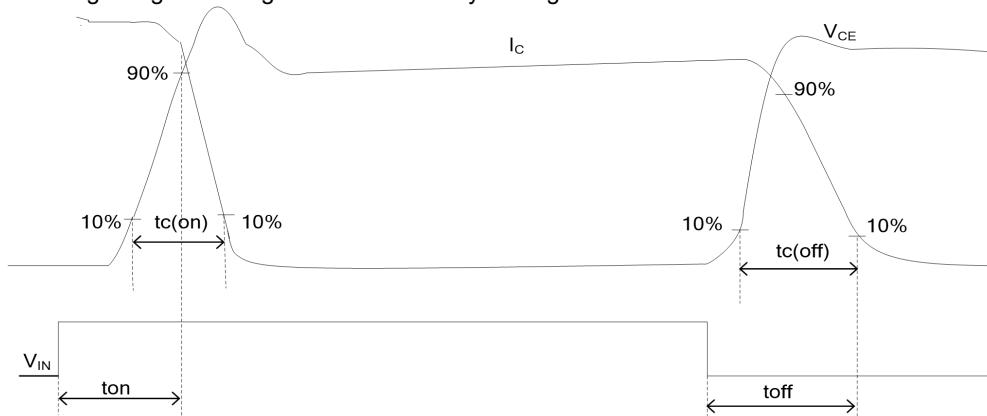

V_{FOH}	故障输出电压 Fault output voltage	$V_{CIN}=0V$, V_{FO} 电路 10K 上拉到 5V V_{FO} circuit: 10K to 5V pull-up	4.9	---	---	V
V_{FOL}		$V_{CIN}=1V$, V_{FO} 电路 10K 上拉到 5V V_{FO} circuit: 10K to 5V pull-up	---	---	0.8	
$V_{CIN(ref)}$	短路保护触发电压 Short circuit trip level	$T_C=-40\sim 100^{\circ}C$, $V_D=15V$ (注 3 / Note3)	0.455	0.480	0.505	
UV_{DLD}	供电电路欠压保护 Supply circuit under-voltage protection	检测电平 (低端) Detection level (LS)	9.0	10.0	11.0	V
UV_{DLR}		复位电平 (低端) Rest level (LS)	10.0	11.0	12.0	
UV_{BSD}		检测电平 (高端) Detection level (HS)	9.0	10.0	11.0	
UV_{BSR}		复位电平 (高端) Rest level (HS)	10.0	11.0	12.0	
t_{FO}	故障信号输出脉冲宽度 Fault-out pulse width		40	---	---	us
V_{OT}	温度输出电压 Voltage of temperature	LVIC $T_J=90^{\circ}C$	2.63	2.77	2.91	V
		LVIC $T_J=25^{\circ}C$	0.88	1.13	1.39	
T_{SD}	过温保护 Temperature shutdown	$V_{D(L)}=15V$, Detect LVIC temperature	100	120	140	$^{\circ}C$
$R_{BS(ON)}$	自举二极管限流电阻 BS driver ON resistance		---	230	---	Ω
$V_{IN(ON)}$	导通阈值电压 ON threshold voltage	施加在 $IN_{(HU)}$, $IN_{(HV)}$, $IN_{(HW)}$ - $COM_{(H)}$, $IN_{(LU)}$, $IN_{(LV)}$, $IN_{(LW)}$ - $COM_{(L)}$ 之间	---	---	3.0	V
$V_{IN(OFF)}$	关断阈值电压 OFF threshold voltage	Applied between $IN_{(HU)}$, $IN_{(HV)}$, $IN_{(HW)}$ - $COM_{(H)}$, $IN_{(LU)}$, $IN_{(LV)}$, $IN_{(LW)}$ - $COM_{(L)}$	0.8	---	---	

注 3 :只有下桥驱动具有短路保护和过温保护功能;

Note3: Only low side has short circuit protection and over temperature protection.

温度模拟输出/ Temperature analog output



图 4. 温度输出电压

Fig 4. Voltage of temperature

机械特性和额定值/Mechanical Characteristics and Ratings

符号 Symbol	工作条件 Conditions		最小值 Min.	典型值 Typ.	最大值 Max.	单位 Units
安装扭矩 Mounting torque	安装螺钉: -M3 Mounting screw: - M3	推荐选用: 0.62N·m Recommended 0.62N.m	0.5	0.62	0.8	N·m
重量 Weight			---	9.3	---	g
器件平面度 Device flatness	参见图 5 (See Fig 5)		---	---	100	um

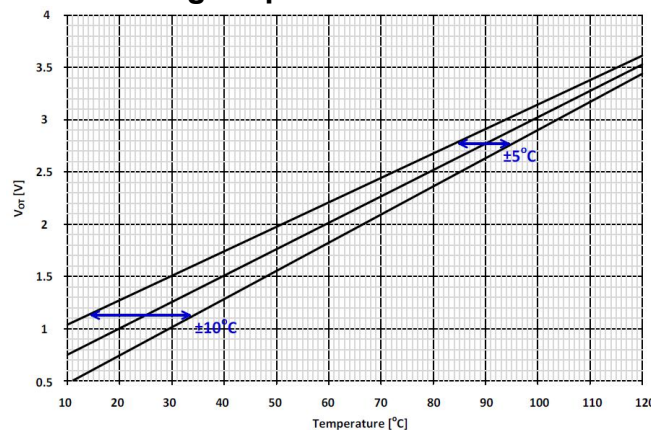

图 5. 平面度测量位置
 Fig 5. Flatness Measurement Position

推荐工作条件/Recommended Operating Conditions

符号 Symbol	参数 Parameter	工作条件 Conditions	最小值 Min.	典型值 Typ.	最大值 Max.	单位 Units
V_{PN}	电源电压 Supply voltage	施加在 P-N _U , N _V , N _W 之间 Applied between P -N _U , N _V , N _W	---	300	400	V
V_D	控制电源电压 Control supply voltage	施加在 V _{D(H)} -COM _(H) , V _{D(L)} -COM _(L) 之间 Applied between V _{D(H)} -COM _(H) , V _{D(L)} -COM _(L)	13.5	15.0	16.5	
V_{DB}	高端控制辅助供电 High side control supply voltage	施加在 V _{B(U)} -U, V _{B(V)} -V, V _{B(W)} -W 之间 Applied between V _{B(U)} -U, V _{B(V)} -V, V _{B(W)} -W	13.5	15.0	18.5	
ΔV_D , ΔV_{DB}	控制电源电压波动 Control supply variation		-1	---	1	V/us
t_{DEAD}	防止桥臂直通的死区时间 Blanking time for preventing arm-short	适用于每个输入信号 For each input signal	1.0	---	---	us
f_{PWM}	PWM 输入信号 PWM input signal	-20°C ≤ T _C ≤ 100°C, -40°C ≤ T _J ≤ 125°C	---	---	20	kHz
V_{SEN}	电流检测产生的电压 Voltage for current sensing	施加在 N _U , N _V , N _W - COM _(L) 之间 (包括浪涌电压) Applied between N _U , N _V , N _W -COM _(L) (Including surge voltage)	-4	---	4	V

IPM 保护功能时序图/Time charts of IPM Protection Function

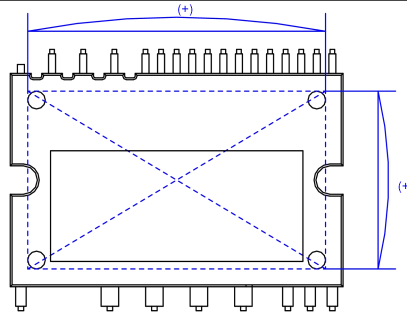
过流保护/Over Current Protection



图 6.过流保护

Fig 6. Over Current Protection

(仅下桥有,包含外部分流电阻和 RC 滤波器)

Low-side only ,with the external shunt resistance and RC filter)

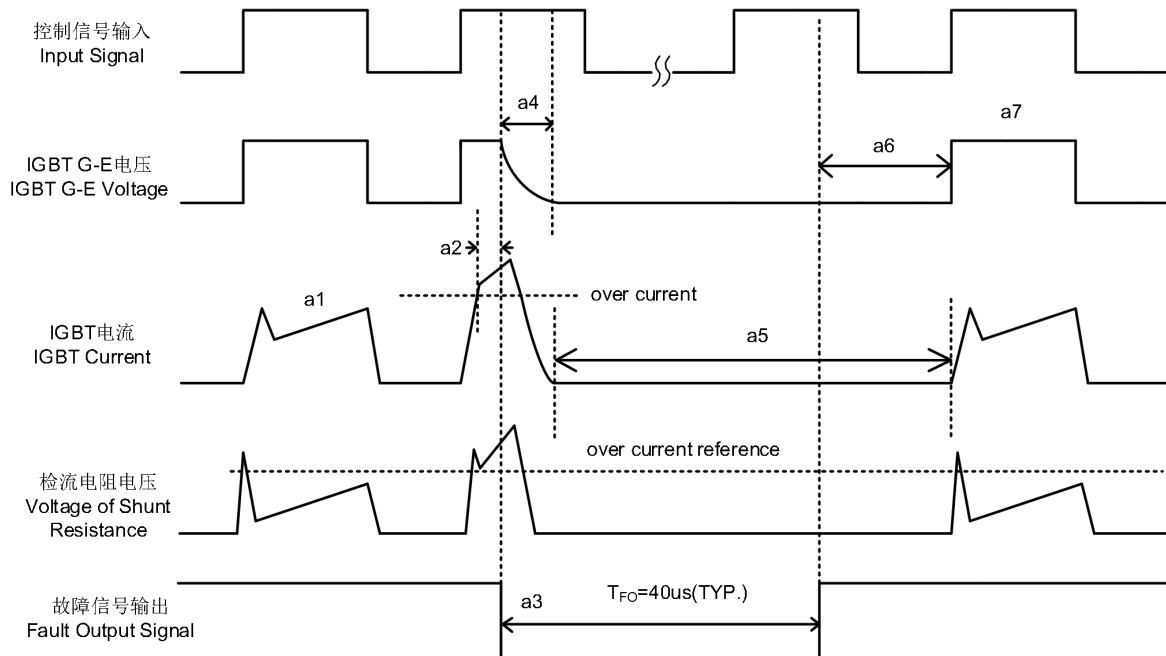
a1 IGBT正常工作, 输出电流

Normal operation: IGBT ON and carrying current

a2 短路电流检测及滤波

Over current detection and filter

a3 故障信号输出开始

Fault output timer operation starts

a4 IGBT关断

IGBT turns off

a5 IGBT处于关断状态

IGBT OFF state

a6 故障信号输出恢复高电平, 但IGBT在下一个高电平输入信号时才会开通

V_{FO} finishes output, but IGBTs don't turn on until inputting next ON signal.

a7 当输入信号由L→H时, IGBT正常工作

Normal operation: IGBT ON and outputs current by next ON signal(L→H).

下桥欠压保护/Under-Voltage Protection of Low-side



图 7. 下桥欠压保护

Fig 7. Under-Voltage Protection of Low-side

- b1 IGBT正常工作，输出电流
Normal operation: IGBT ON and carrying current
- b2 欠压保护检测 (UV_{DLD})
Under voltage detection (UV_{DLD})
- b3 故障信号输出低电平
Fault output timer operation starts
- b4 欠压恢复 (UV_{DLR})
Under voltage reset (UV_{DLR})
- b5 IGBT处于关断状态
IGBT OFF state
- b6 故障信号输出恢复高电平，但IGBT在下一个高电平输入信号时才会开通
 V_{FO} finishes output, but IGBTs don't turn on until inputting next ON signal.
- b7 当输入信号由L→H时，IGBT正常工作
Normal operation: IGBT ON and outputs current by next ON signal(L→H).

上桥欠压保护/Under-Voltage Protection of High-side

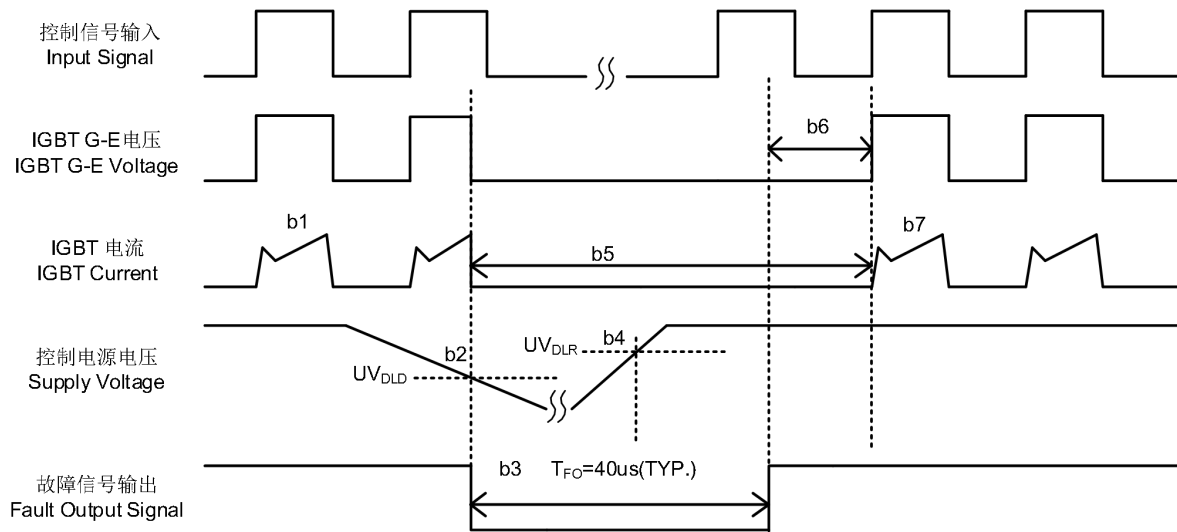

图 8. 上桥欠压保护

Fig 8. Under-Voltage Protection of High-side

- c1 IGBT正常工作，输出电流
Normal operation: IGBT ON and carrying current
- c2 欠压保护检测 (UV_{BSD})
Under voltage detection (UV_{BSD})
- c3 故障信号保持高电平，上桥欠压无故障信号输出
No fault output signal
- c4 欠压恢复 (UV_{BSR})
Under voltage reset (UV_{BSR})
- c5 IGBT处于关断状态
IGBT OFF state
- c6 欠压已恢复，但IGBT在下一个高电平输入信号时才会开通
Under voltage reset, but IGBTs don't turn on until inputting next ON signal.
- c7 当输入信号由L→H时，IGBT正常工作
Normal operation: IGBT ON and outputs current by next ON signal(L→H).

典型应用电路/Typical Application Circuit

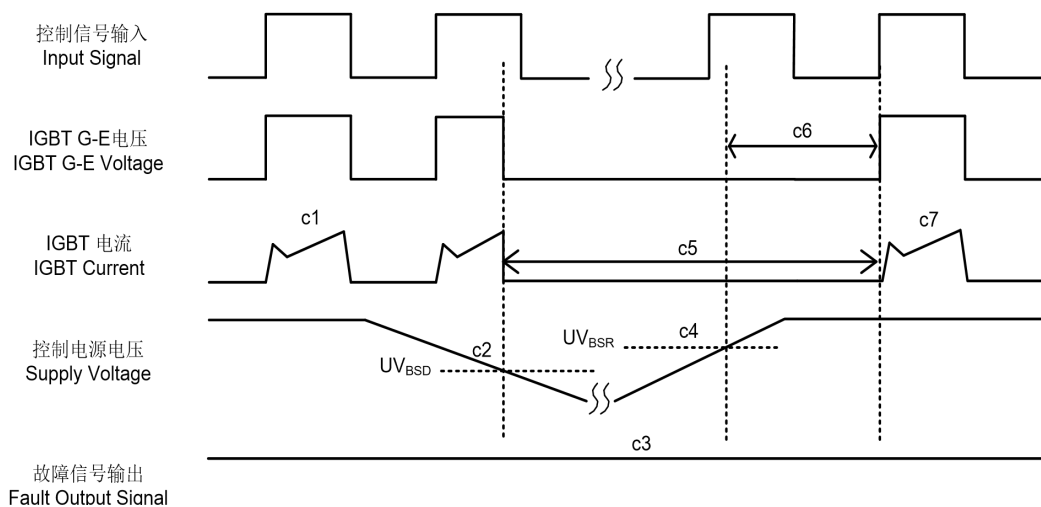

图 9.典型应用电路
Fig 9. Typical Application Circuit



1. 驱动输入信号高电平有效，为防止发生误动作，输入布线应尽可能短，当使用RC滤波电路时，须确保输入信号达到开启和关断阈值电压范围。

Input drive is High-Active type, to prevent malfunction, the wiring of each input should be as short as possible. When using RC Filter circuit, make sure the input signal level meet the turn-on and turn-off threshold voltage.

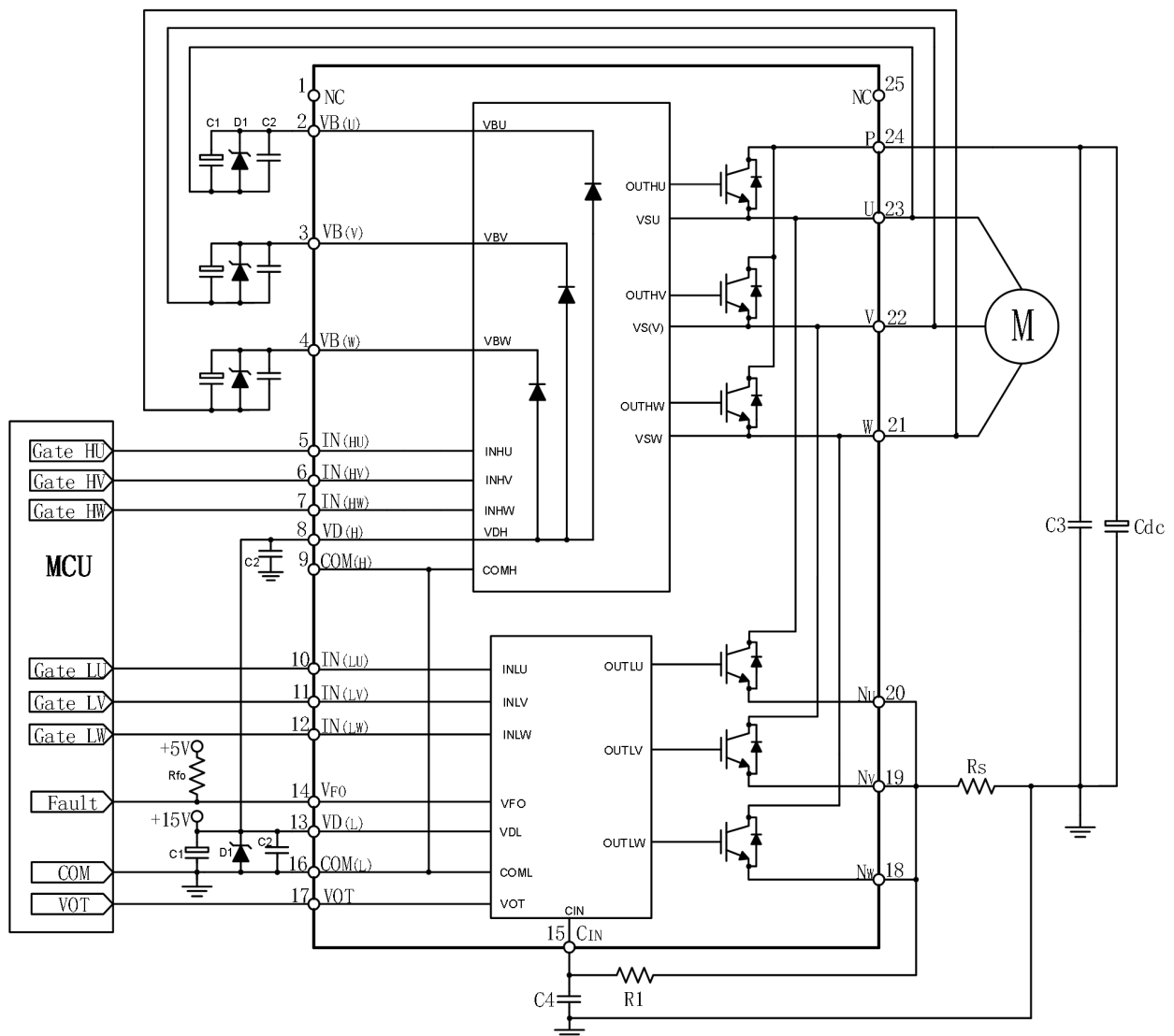
2. 由于模块内置了专用HVIC，其控制端子可与MCU端子直接相连，而不需要任何光耦或变压器等隔离电路。

As the module has a dedicated HVIC, direct coupling to MCU without any opto-coupler or transformer isolation is possible.

3. 自举电路负极应直接连接到U、V、W的端。

Bootstrap negative electrodes should be connected to U, V, W terminals directly and separated from the main output wires.

4. VFO是漏极开路型，其信号线应通过一个约10kΩ的上拉电阻上拉到+5V/3.3V电源。

VFO output is open drain type. It should be pulled up to the positive side of a 5V/3.3V power supply by a resistor of about 10kΩ.

5. 保护线路R1、C4的时间常数建议选取在1~2μS。关断时间可能随着布线的不同而多少有些变化。建议R1、C4选择小容差、温度补偿类型。

The time constant R1、C4 of the protection circuit should be selected in the range of 1.0-2μs. SC interrupting time might vary with the wiring pattern. Tight tolerance, temp-compensated type is recommended for R1,C5.

6. 所有电容的位置尽可能的靠近IPM。

All capacitors should be mounted as close to the terminals of the IPM as possible.

7. 为了防止噪声干扰，储能电容与P&N之间的引线应尽可能的短，推荐在P&N端子之间加约0.1~0.22μF的MLCC低频滤波电容。

To prevent surge destruction, the wiring between the smoothing capacitor and the P&N terminals should be as short as possible. Generally, a 0.1-0.22μF snubber between the P&N terminals is recommended

8. 两个COM端（9&16脚）在IPM内部已连接在一起，外部任一COM端子连接到GND，另一端子允许开路。

Two COM terminals (9 & 16 pin) are connected inside IPM, please connect either one to the power supply GND outside and leave another one open.

9. 如果控制地通过PCB走线被连接到功率地，控制信号可能会受到功率地的起伏的影响，推荐使用单点连接。

If control GND is connected to power GND by broad pattern, it may cause malfunction by power GND fluctuation. It is recommended to connect control GND and power GND at only one point.



封装轮廓详图/Detailed Package Outline Drawings

封装/Package: BIP25-3824

(单位/Unit: mm)



图 9. 封装轮廓详图

Fig 9. Detailed Package Outline Drawings

包装/Packing

包装 package	pcs/料管 pcs/tube	料管/内盒 tube/ inner box	内盒/箱 inner box/ carton	pcs/箱 pcs/carton
料管/tube	12	6	5	360

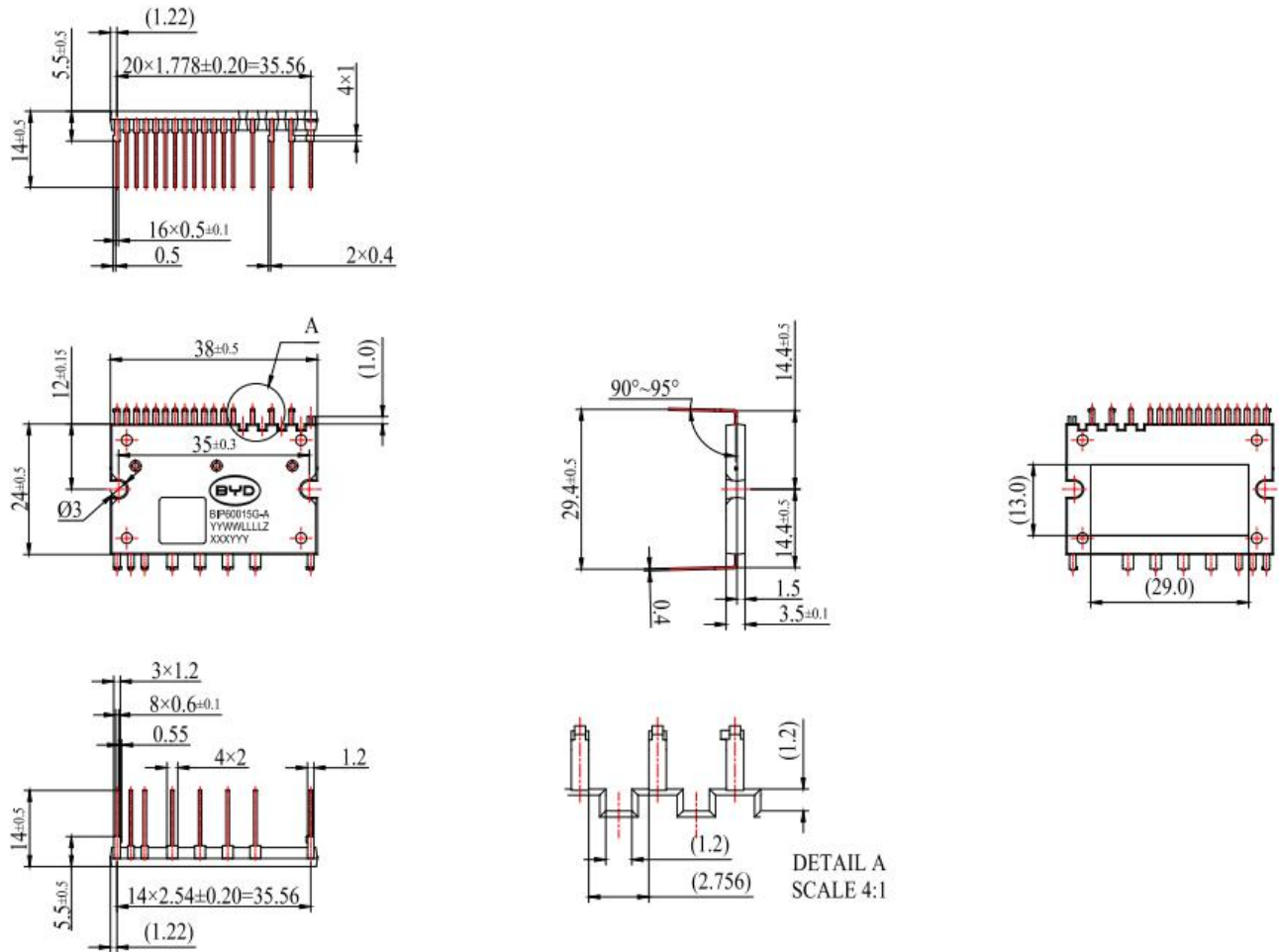

产品使用须知/RESTRICTIONS ON PRODUCT USE

- 本资料内容随产品的改进，可能会有未经预告之修改，比亚迪半导体拥有优先修改权。
- 尽管本公司一向致力于提高产品质量和可靠性，但是半导体产品有可能按某种概率发生故障或错误工作，为防止因故障或错误工作而产生人身事故，火灾事故，社会性损害等，请充分留意冗余设计、火灾蔓延对策设计、防止错误动作设计等安全设计。
- 本文所列比亚迪产品仅可应用于计算机、个人设备、办公设备、测量设备、工业机器人臂、家用电器等通用电气设备中，不可用于对精度、可靠性要求极高的设备中，也不可应用于会造成人身伤亡的设备中，不可用设备包括但不限于原子能控制器、航空航天设备、医疗设备与其他安环设备，对产品不恰当的使用将由使用者承担可能存在的风险。

- The information contained herein is subject to change without notice.
- BYD Semiconductor Co., Ltd. exerts the greatest possible effort to ensure high quality and reliability. Nevertheless, semiconductor devices in general can malfunction or fail due to their inherent electrical sensitivity and vulnerability to physical stress. It is the responsibility of the buyer, when utilizing BYD products, to comply with the standards of safety in making a safe design for the entire system, including redundancy, fire-prevention measures, and malfunction prevention, to prevent any accidents, fires, or community damage that may ensue. In developing your designs, please ensure that BYD products are used within specified operating ranges as set forth in the most recent BYD products specifications.
- The BYD products listed in this document are intended for usage in general electronics applications (computer, personal equipment, office equipment, measuring equipment, industrial robotics, domestic appliances, etc.). These BYD products are neither intended nor warranted for usage in equipment that requires extraordinarily high quality and/or reliability or a malfunction or failure of which may cause loss of human life or bodily injury ("Unintended Usage"). Unintended Usage include atomic energy control instruments, airplane or spaceship instruments, transportation instruments, traffic signal instruments, combustion control instruments, medical instruments, all types of safety devices, etc.. Unintended Usage of BYD products listed in this document shall be made at the customer's own risk.